

EUROMAP 101.1	<p>Submodel Template of the Asset Administration Shell Plastics and Rubber Moulds Part 1: Identification</p>
----------------------	---

Version Draft 1.0, March 2025
12 pages

**EUROMAP 101.1 (Draft 1.0) is identical with
IDTA 02038-1 “Plastic and Rubber Moulds, Part 1: Identification”
(Version 1.0, March 2025)**

History

Date	Changes
2025-03-24	<i>Publication of draft 1.0</i>

Contents		Page
1	General	4
1.1	About this document.....	4
1.2	Scope of the Submodel	4
1.3	Relevant standards for the Submodel template	4
1.4	Use cases, requirements and design decisions	5
2	Submodel PlasticsAndRubberMouldsIdentification	6
2.1	Approach.....	6
2.2	UML Diagram of Submodel.....	6
2.3	Attributes for the Submodel “PlasticsAndRubberMouldsIdentification”	8

1 General

1.1 About this document

This document is a part of a specification series. Each part specifies the contents of a Submodel template for the Asset Administration Shell (AAS). The AAS is described in [1], [2], [3] and [6]. First exemplary Submodel contents were described in [4], while the actual format of this document was derived by the "Administration Shell in Practice" [5]. The format aims to be very concise, giving only minimal necessary information for applying a Submodel template, while leaving deeper descriptions and specification of concepts, structures and mapping to the respective documents [1] to [6].

The target group of the specification are developers and editors of technical documentation and manufacturer information, which are describing assets in smart manufacturing by means of the Asset Administration Shell (AAS) and therefore need to create a Submodel instance with a hierarchy of SubmodelElements. This document especially details on the question, which SubmodelElements with which semantic identification shall be used for this purpose.

This document was developed by a Joint Working Group (JWG) consisting of members of IDTA and EUROMAP. This document is identical to EUROMAP 101.1.

EUROMAP is the European umbrella association of the plastics and rubber machinery industry which accounts for annual sales of around 13.5 billion euro and a 40 per cent share of worldwide production. Almost 75 per cent of its European output is shipped to worldwide destinations. With global exports of 10.0 billion euro, EUROMAP's around 1,000 machinery manufacturers are market leaders with nearly half of all machines sold being supplied by EUROMAP members.

EUROMAP provides technical recommendations for plastics and rubber machines. These guidelines encompass standards for machine descriptions, dimensions, electrical interfaces and energy measurement. Additionally, they include Industry 4.0 standards such as OPC UA and AAS, ensuring high levels of machine compatibility.

This document is a part of the specification series IDTA 02038 (identical to EUROMAP 101 series) describing plastics and rubber moulds. This series consist of the following submodel templates, of which some may still be under development (further specifications are possible):

- Part 1: Identification of plastic and rubber moulds
- Part 2: Engineering data of plastic and rubber moulds
- Part 3: Plastic and rubber mould configuration data
- Part 4: Plastic and rubber mould production parameters
- Part 5: Plastic and rubber mould collaborative condition monitoring

1.2 Scope of the Submodel

This specification applies to moulds used in plastics and rubber production machines. The Submodel is part of the mould's digital twin, offering detailed information for mould identification, as these components often require additional information compared to machines or devices.

1.3 Relevant standards for the Submodel template

Following standards are relevant for application of this Submodel template:

IDTA 02006-3-0: Digital Nameplate for Industrial Equipment

<https://admin-shell.io/idta/nameplate/3/0/Nameplate>

IDTA 02002-1-0: Submodel for Contact Information

<https://admin-shell.io/zvei/nameplate/1/0/ContactInformations>

OPC 40083: OPC UA for Plastics and Rubber Machinery – General Type Definitions
(identical to EUROMAP 83 and VDMA 40083)

<http://opcfoundation.org/UA/PlasticsRubber/GeneralTypes/>

OPC 40082-5: OPC UA interfaces for plastics and rubber machinery – Peripheral devices –
Part 5: Moulds

(identical to EUROMAP 82.5 and VDMA 40082-5)

<http://opcfoundation.org/UA/PlasticsRubber/Moulds>

1.4 Use cases, requirements and design decisions

The use case of this submodel is to provide additional information required for the identification of plastics and rubber moulds. This includes details about the product produced on the mould (also referred to as “Article”), as well as the mould (component) name and installation location specified by the end user. Since moulds are often owned by the product owner (customer) rather than the production company where the mould is located, additional contact information is necessary.

As this Submodel Template complements the Digital Nameplate, the Submodel 'IDTA 02006-3-0: Digital Nameplate for Industrial Equipment' must be deployed when applying this Submodel. Additionally, the Submodel 'IDTA 02004-1-2 Handover Documentation' should be deployed.

2 Submodel PlasticsAndRubberMouldsIdentification

2.1 Approach

This Submodel Template was developed by the same working group that created the OPC UA Companion Specification 'OPC 40082-5: OPC UA interfaces for plastics and rubber machinery – Peripheral devices – Part 5: Moulds'. Since mould parameters need to be accessible even when the mould controller is switched off and the mould is stored, deploying the digital twin on an edge device is ideal.

The working group decided to handle dynamic data, such as process values, through OPC UA, while static or lifecycle data, like counters and maintenance information, are managed via the Asset Administration Shell (AAS). Both technologies are designed to be used independently, meaning the AAS can be utilized even if no OPC UA server is implemented on the mould controller, and vice versa. Consequently, some overlap in property definitions is unavoidable.

To streamline the revision process of the submodels, the group decided to develop multiple AAS Submodel Templates for moulds, including Identification, Engineering Data, Mould Configuration, Production Parameters, and Collaborative Condition Monitoring. Each SMT can be applied independently, but the Digital Nameplate and Identification shall always be used.

The purpose of this submodel is to provide additional information necessary for identifying plastics and rubber moulds. Since moulds are often owned by the product owner rather than the company where the mould is located, additional contact information is required. For this parameter collection, the Submodel Template 'IDTA 02002-1-0: Submodel for Contact Information' is used as a drop-in.

2.2 UML Diagram of Submodel

Figure 1 shows the UML Diagram of the Submodel PlasticsAndRubberMouldsIdentification without any Submodel Element Collections (SMC).

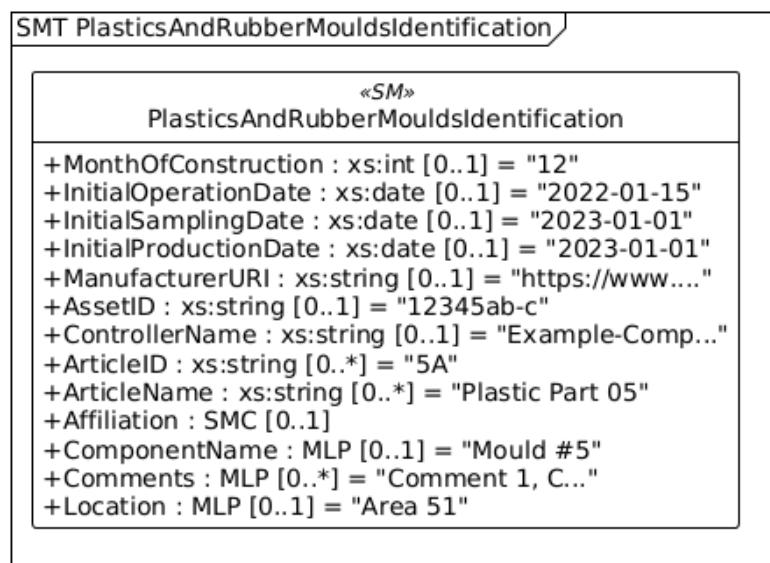

Figure 1: UML Diagram of SM PlasticsAndRubberMouldsIdentification

Figure 2 shows the UML Diagram of the Submodel PlasticsAndRubberMouldsIdentification with the corresponding SMCs.

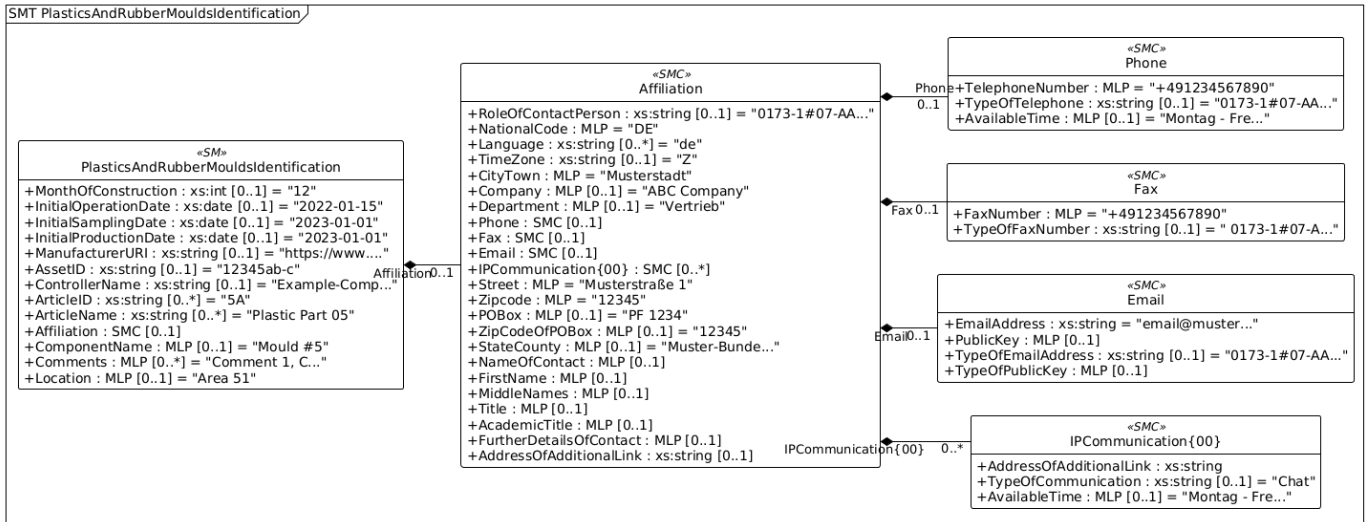

Figure 2: UML Diagram of SM PlasticsAndRubberMouldsIdentification with SMCs

2.3 Attributes for the Submodel “PlasticsAndRubberMouldsIdentification”

The following attributes need to be set for the Submodel instance.

Table 1: Attributes of the Submodel Instance

idShort:	PlasticsAndRubberMouldsIdentification		
Class:	Submodel (SM)		
semanticId:	[IRI] https://admin-shell.io/idta/euromap/SubmodelTemplate/Moulds/Identification/1/0		
Parent:	-		
Explanation:	The Submodel defines Identification parameters to be used in addition to the Digital Nameplate Submodel.		
[SME type]	semanticId = [idType]value	[valueType]	card.
idShort	Description @en	example	
[Prop] MonthOfConstruction	[IRDI] 0173-1#02-ABA682#001 The month in which the manufacturing process of the machine has been completed	[Int]	0..1
[Prop] InitialOperationDate	[IRDI] 0173-1#02-ABA683#001 Initial operation date date, when the machine was switched on the first time after it has left the manufacturer plant The first time, the mould gets on the machine and switched on (dry cycle)	[Date]	0..1
[Prop] InitialSamplingDate	[IRI] https://admin-shell.io/idta/euromap/Moulds/Identification/InitialSamplingDate/1/0 The date, when the mould was used in an IMM for the first time (FOT - first part out of tool)	[Date]	0..1
[Prop] InitialProductionDate	[IRI] https://admin-shell.io/idta/euromap/Moulds/Identification/InitialProductionDate/1/0 The date, when the mould was transferred to series production the first time	[Date]	0..1
[Prop] ManufacturerURI	[IRI] https://admin-shell.io/idta/euromap/Moulds/Identification/ManufacturerURI/1/0 A globally unique identifier of the manufacturer of the MachineryItem.	[String]	0..1
[Prop] AssetID	[IRDI] 0173-1#02-ABA684#001 To be used by end users to store a unique identification in the context of their overall application.	[String]	0..1
[Prop]	[IRI] https://admin-shell.io/idta/euromap/Moulds/Identification/1/0	[String]	0..1

ControllerName	shell.io/idta/euromap/Moulds/Identification/ControllerName/1/0 The ControllerName Property represents the name of the machine controller (e.g. "MC5").		
[Prop] ArticleID	[IRI] https://admin-shell.io/idta/euromap/Moulds/Identification/ArticleID/1/0 ID of the article (plastic part), which is produced with the mould. Given by the end user	[String]	0..*
[Prop] ArticleName	[IRI] https://admin-shell.io/idta/euromap/Moulds/Identification/ArticleName/1/0 Name of the plastic part, which is produced with the mould	[String]	0..*
[SMC] Affiliation	[IRI] https://admin-shell.io/zvei/nameplate/1/0/ContactInformations/ContactInformation The SMC "Affiliation" provides information about the owner of the mould. It has the same CD as "ContactInformation"	[-]	0..1
[MLP] Component Name	[IRDI] 0173-1#02-ABA685#001 To be used by end users to store a human-readable localized text for the name of the mould. The minimum number of locales supported for this property shall be two.	[-]	0..1
[MLP] Comments	[IRDI] 0173-1#02-ABJ035#002 To be used by end users to store comments in a scheme specific to the end user.	[-]	0..*
[MLP] Location	[IRDI] 0173-1#02-ABA686#001 To be used by end users to store the location of the machine in a scheme specific to the end user.	[-]	0..1

Annex A. Explanations on used table formats

1. General

The used tables in this document try to outline information as concise as possible. They do not convey all information on Submodels and SubmodelElements. For this purpose, the definitive definitions are given by a separate file in form of an AASX file of the Submodel template and its elements.

2. Tables on Submodels and SubmodelElements

For clarity and brevity, a set of rules is used for the tables for describing Submodels and SubmodelElements.

- The tables follow in principle the same conventions as in [5].
- The table heads abbreviate 'cardinality' with 'card'.
- The tables often place two informations in different rows of the same table cell. In this case, the first information is marked out by sharp brackets [] from the second information. A special case are the semanticIds, which are marked out by the format: (type)(local)[idType]value.
- The types of SubmodelElements are abbreviated:

SME type	SubmodelElement type
Property	Property
MLP	MultiLanguageProperty
Range	Range
File	File
Blob	Blob
Ref	ReferenceElement
Rel	RelationshipElement
SMC	SubmodelElementCollection

- If an idShort ends with '__00__', this indicates a suffix of the respective length (here: 2) of decimal digits, in order to make the idShort unique. A different idShort might be chosen, as long as it is unique in the parent's context.
- The Keys of semanticId in the main section feature only idType and value, such as: [IRI]https://admin-shell.io/vdi/2770/1/0/DocumentId/Id. The attributes "type" and "local" (typically "ConceptDescription" and "(local)" or "GlobalReference" and (no-local)) need to be set accordingly; see [6].
- If a table does not contain a column with "parent" heading, all represented attributes share the same parent. This parent is denoted in the head of the table.
- Multi-language strings are represented by the text value, followed by '@'-character and the ISO 639 language code: example@EN.
- The [valueType] is only given for Properties.

Bibliography

- [1] “Recommendations for implementing the strategic initiative INDUSTRIE 4.0”, acatech, April 2013. [Online]. Available <https://www.acatech.de/Publikation/recommendations-for-implementing-the-strategic-initiative-industrie-4-0-final-report-of-the-industrie-4-0-working-group/>
- [2] “Implementation Strategy Industrie 4.0: Report on the results of the Industrie 4.0 Platform”; BITKOM e.V. / VDMA e.V., /ZVEI e.V., April 2015. [Online]. Available: <https://www.bitkom.org/noindex/Publikationen/2016/Sonstiges/Implementation-Strategy-Industrie-40/2016-01-Implementation-Strategy-Industrie40.pdf>
- [3] “The Structure of the Administration Shell: TRILATERAL PERSPECTIVES from France, Italy and Germany”, March 2018, [Online]. Available: <https://www.plattform-i40.de/I40/Redaktion/EN/Downloads/Publikation/hm-2018-trilaterale-coop.html>
- [4] “Beispiele zur Verwaltungsschale der Industrie 4.0-Komponente – Basisteil (German)”; ZVEI e.V., Whitepaper, November 2016. [Online]. Available: <https://www.zvei.org/presse-medien/publikationen/beispiele-zur-verwaltungsschale-der-industrie-40-komponente-basisteil/>
- [5] “Verwaltungsschale in der Praxis. Wie definiere ich Teilmodelle, beispielhafte Teilmodelle und Interaktion zwischen Verwaltungsschalen (in German)”, Version 1.0, April 2019, Plattform Industrie 4.0 in Kooperation mit VDE GMA Fachausschuss 7.20, Federal Ministry for Economic Affairs and Energy (BMWi), Available: <https://www.plattform-i40.de/PI40/Redaktion/DE/Downloads/Publikation/2019-verwaltungsschale-in-der-praxis.html>
- [6] “Details of the Asset Administration Shell; Part 1 - The exchange of information between partners in the value chain of Industrie 4.0 (Version 3.0RC01)”, November 2020, [Online]. Available: <https://www.plattform-i40.de/PI40/Redaktion/EN/Downloads/Publikation/Details-of-the-Asset-Administration-Shell-Part1.html>

EUROMAP

Europäisches Komitee der Hersteller von Kunststoff- und Gummi-
maschinen

European Committee of Machinery Manufacturers for the Plastics
and Rubber Industries

Comité Européen des Constructeurs de Machines pour Plastiques
et Caoutchouc

Comitato Europeo Costruttori Macchine per Materie Plastiche e
Gomma

See you again

<http://www.euromap.org>

Copyright by EUROMAP